

Designed and manufactured with 8 exclusive patented technologies, Narada have created an innovative range of high temperature batteries. The 313K series is designed to cope with the most extreme temperatures and environments. The advanced technology and unique manufacturing methods enable 313K batteries to deliver at least twice the cycle life of conventional lead- acid batteries, making them the first choice increasing power demands in remote hybrid telecom sites and other tough off-grid applications.

Standards

Test standards

IEC60896-21/-22, IEC61427, YD/T799 etc.

Safety standard, ventilation

EN 50272-2

Manufactured under system

ISO9001/TL9000& ISO 14001 by Narada

Benefits

- Excellent deep cycling capability
- Suitable for continuous operation at temperatures in excess of 35°C
- Reduced system operating costs
- 25% electricity power saving
- Up to 100% air conditioner maintenance saving
- Up to 100% condensing agent saving
- 30% CO2 gas emission reduce
- Less than 1 year payback period depend on environment



Technical specifications

Electrical data

Nominal voltage	2 V
Number of cells	1
Rated capacity	200Ah -20A for 10h to 1.80V/cell(25°C) 210Ah - 21.0A for 10h to 1.80V/cell(35°C)
Internal resistance	0.55mΩ(acc.to IEC 60896-21)
Short circuit current	3700 A(acc.to IEC 60896-21)
Self disc harge(35°C)	less than 5% per month
Design life at 35°C	15years

Mechanical data

Weigh ready for use	17 kg(37.5 lbs)
Length	227 mm(8.94 in)
Width	96 mm(3.75 in)
Height of monobloc	291 mm(11.46 in)
Total height	303 mm(11.93 in)
Terminal	M8 female
Terminal hardware torque	1 0 -12Nm

Constant Current Discharge Date Units:Amperes(35°C,95°F)

End Voltage	15 min	30 min	60 min	3 hour	5 hour	8 hour	10 hour	24 hour	48 hour	72 hour	120 hour	240 hour
1.75V	236.1	173.0	115.4	53.0	36.8	25.8	21.5	9.58	4.95	3.39	2.15	1.11
1.80V	222.6	161.9	108.0	51.4	36.0	25.3	21.0	9.42	4.83	3.23	2.10	1.08
1.83V	209.0	154.1	101.2	49.8	35.1	24.9	20.6	9.22	4.73	3.24	2.06	1.06
1.85V	197.4	144.4	97.5	48.8	34.8	24.6	20.4	9.11	4.71	3.22	2.04	1.05
1.88V	180.0	135.6	93.4	47.7	34.4	24.3	20.3	9.03	4.67	3.19	2.03	1.04
1.90V	166.9	123.8	86.6	45.7	33.5	23.6	19.8	8.91	4.55	3.11	1.98	1.02

Constant Power Discharge Date Units:Wants per cell(35°C,95°F)

End Voltage	5 min	15 min	30 min	60 min	90 min	2 hour	3 hour	4 hour	5 hour	6 hour	8 hour	10 hour	12 hour	24 hour
1.70V	530.0	449.4	356.5	242.4	190.4	158.3	113.2	91.4	77.9	67.0	52.0	42.7	38.8	19.5
1.75V	513.5	432.5	344.4	233.0	184.7	152.7	109.0	89.5	76.0	65.4	50.0	42.0	38.2	19.3
1.80V	499.3	412.2	332.2	227.5	180.3	149.9	105.2	86.6	73.9	63.5	48.8	41.4	37.7	19.1
1.83V	472.0	393.3	313.3	219.4	174.2	143.8	102.6	85.3	72.4	61.6	47.8	40.6	36.9	18.8
1.85V	454.1	375.4	295.4	207.0	167.3	137.7	99.6	83.3	70.4	60.1	47.1	39.8	36.2	18.3
1.88V	428.8	375.4	274.7	194.5	154.6	128.0	96.2	80.4	68.1	58.0	45.9	38.8	35.3	17.8
1.90V	400.7	325.8	249.2	178.3	143.4	119.5	92.4	77.5	65.8	56.2	44.1	36.9	33.6	17.1
1.94V	362.3	291.7	223.2	158.0	128.4	110.4	85.8	72.6	62.3	53.9	42.3	35.3	32.2	16.9

Construction

Positive plate	Reinforced grids in a corrosion-resistant pure lead, high tin, low calcium alloy
Negative plate	Lead-calcium alloy grid
Separator	High density microporous glass mat with low electrical resistance
Container & lid	High temperature ABS. Optional flame retardant versions available (UL94 FV-0 with L.O.I. of 28%)
Electrolyte	Sulphuric acid with a density of 1.28g/ml absorbed in AGM
Terminal design	Patented leak resistant seal configuration with brass insert
Safety valve	Calibrated opening pressure, the valve equipped with flame arrestors for increased operational safety and service life.

Dimensions (mm)

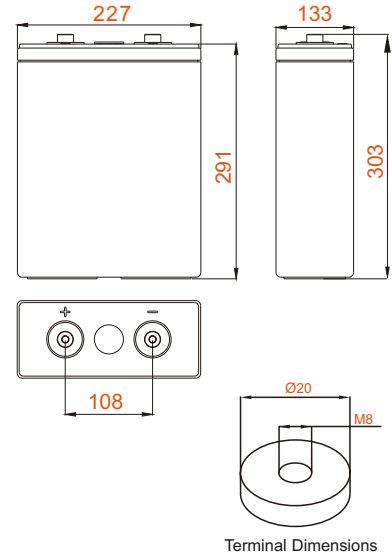

Installation and operation

- Recommended float charge voltage compensation in function of temperature: 2.24V per cell at 35°C -3mV/°C /cell
- Cycle and equalize charge voltage: 2.30V per cell at 35°C, or case by case compensation in function of temperature: -5mV/°C /cell
- CC-CV charge current: unlimited, otherwise 0.25C10A max. if T>25°C
- Preferred operating temperature range: 15°C to 35°C (68°F to 95°F)
- Maximum operating temperature range: -40°C to 80°C (-40°F to 176°F)
- A separate battery room: is not necessary
- Reduced maintenance: no water addition required

Racking (optional)

Narada racks are constructed using strong, easy to assemble, powder-coated steel tubing and come complete with sliding cover terminal (take-off) plates.

Cell model:	HTB-200		
Number of cells:	24		
System Voltage:	48		
Cell Configuration	4 high 6 wide	6 high 4 wide	In coolstar cabinet
Rack width (mm)	1622	1048	Cabinet width (1200)
Rack depth (mm)	300	300	Cabinet depth (1450)
Rack height (mm)	624	886	Cabinet height (1500)
System weight (kg)	490	480	650

