

ICS series

ICS-1000

Narada's ICS series battery designed to provide highcycling and fast charge performance, idea for telecom service where power supply is unstable. With innovative structure design, high quality manufacturing and high quality material, ICS batteries are also capable of PSoC, hybrid, renewable energy storage application and other cycling/standby applications.



Specifications

Battery Model	ICS-1000	
Nominal voltage	2V	
Capacity	1000Ah (10HR, 100A, 1.80V, 25°C)	
Approx.Weight	65.5kg	
Internal Resistance	Approx 0.20mΩ	
Max Charge Current Allowed	250A	
Charge Voltage (25°C)	Cycle use	Float use
	2.35V/cell	2.25V/cell
Temperature Ranges	Operation(maximum): -40°C to 55°C (-40°F to 131°F)	
	Operation(recommended): 15°C to 25°C (59°F to 77°F)	
	Storage: -20°C to 40°C (-4°F to 104°F)	
Terminal	M8 Female	
Terminal Hardware	15 ± 1.0 N.m	
Container Material	ABS (V0 optional)	

Dimensions (mm)

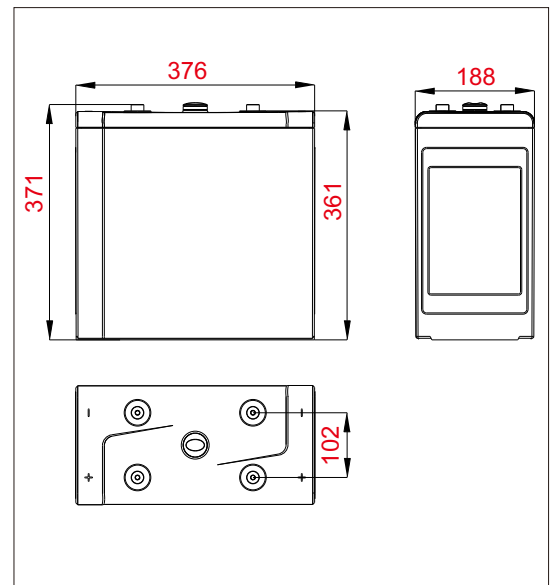

Constant Current Discharge Data Units: Amperes (25°C, 77°F)

End voltage per cell	15min	20min	30min	40min	50min	1h	2h	3h	5h	8h	10h
1.65V	1180	1080	870	750	660	565	340	260	175	126	108
1.70V	1100	1010	830	720	640	560	337	257	170	120	106
1.75V	1020	920	780	680	600	555	335	255	168	116	104
1.80V	890	820	730	640	565	552	333	252	166	112	102

Constant Power Discharge Data Units: Watts per cell (25°C, 77°F)

End voltage per cell	15min	20min	30min	40min	50min	1h	2h	3h	5h	8h	10h
1.65V	2200	1980	1690	1400	1270	1080	720	560	405	288	255
1.70V	2050	1890	1580	1360	1180	1040	705	545	380	265	240
1.75V	1950	1780	1480	1280	1100	990	690	535	360	245	230
1.80V	1780	1600	1370	1190	1020	960	665	510	330	221	205

ICS series

ICS-1000

Discharge Voltage vs Time Curve (25°C)

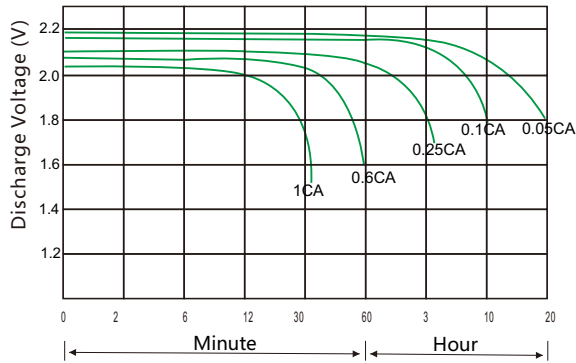

Charge Curve (25°C)

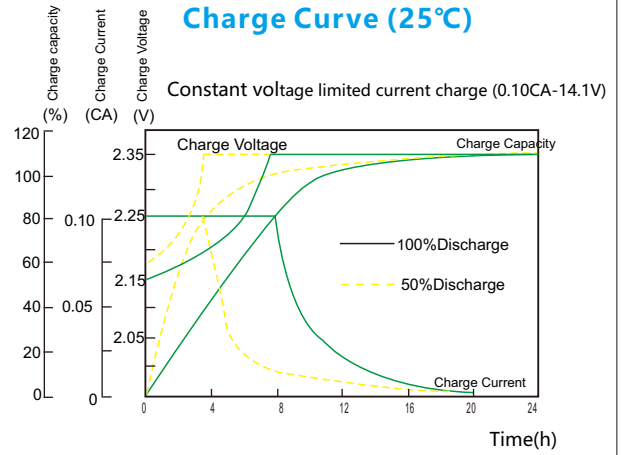

Capacity vs temperature curve

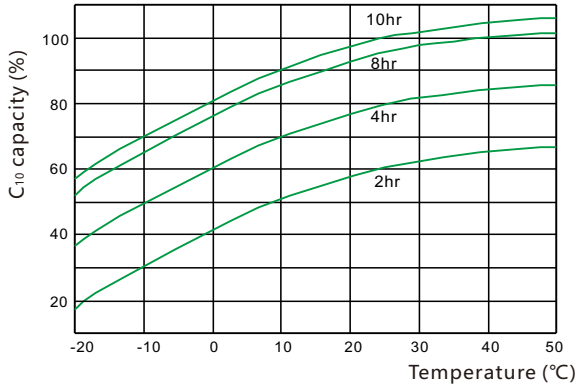

Residual Capacity vs Storage Time

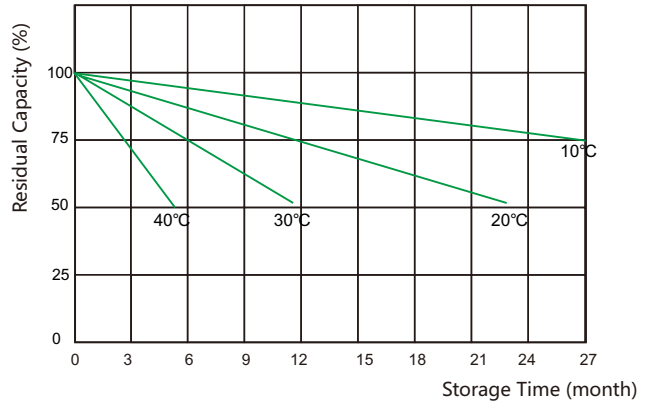

Capacity vs OCV curve

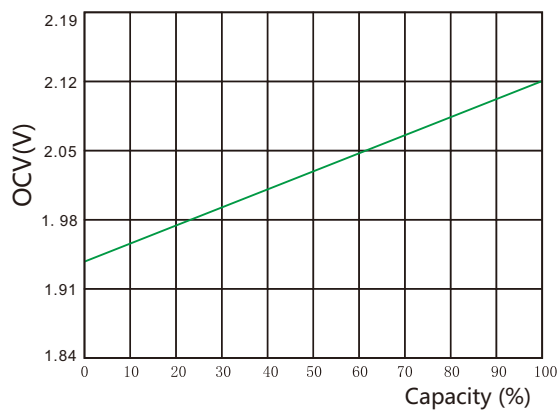

Design life vs temperature

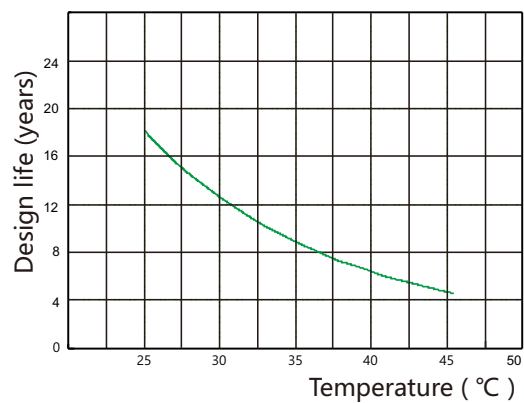

ABDULMAJEED AL-WAHBANI TRADING GROUP (ATG)
 YEMEN SANA'A HADA STREET NEAR AL-GARASI BUILDING
 TEL: 211764 MOB: 777222725
 WEB SITE WWW.ATG-YE.COM
 E-MAIL INFO@ ATG-YE.COM

مجموعة عبدالمجيد الوهباني للتجارة
 اليمن - صنعاء - حدة جوار عمارة الغراسي
 تلفاكس / جوال 211764 / 777222725
 الموقع الالكتروني WWW.ATG-YE.COM
 البريد الالكتروني INFO@ ATG-YE.COM